



扫一扫
关注安徽金纬挤出微信

**安徽金纬挤出设备
有限公司**

安徽省滁州市全椒县十字镇
十潭产业园 邮编: 239000

电话: 15806226098

**ANHUI JWELL EXTRUSION
MACHINERY CO., LTD.**

Shitan Industrial Park, Shizi Town, Quanjiao County,
Chuzhou City, Anhui Province, China. 239000

Tel: +86-15806226098

E-mail: infyca@jwell.cn sales@jwell.cn
Complaint E-mail: info@jwell.cn



**EXTRUSION
MACHINERY**



安徽金纬挤出设备有限公司
ANHUI JWELL EXTRUSION MACHINERY CO.,LTD.

ANHUI JWELL MACHINERY

安徽金纬简介



金纬机械安徽全椒厂区是金纬机械旗下又一重要发展战略基地，坐落于风景秀美的滁州市全椒县，地理位置靠近合肥和南京，高铁交通方便。金纬机械创建于1997年，中国塑料机械工业协会副会长单位，塑料挤出机械和化纤纺丝成套设备专业制造商，现有安徽全椒、浙江海宁、苏州太仓、常州溧阳、上海嘉定、浙江舟山、广东佛山、泰国曼谷等八个生产基地，占地面积1000+亩，旗下拥有26个专业公司以及九个大型金加工车间和三个热处理氮化车间，每年生产3000+(台)套高档的塑料挤出生产线和其他成套设备。畅销120多个国家和地区。



“品质卓越 完美如一” 是金纬公司的质量方针，是全体员工努力的方向。

“诚实待人” 是我们铸就“百年金纬”的核心理念。

董事长：何海潮 Email: he@jwell.cn

Anhui Quanjiao plant of Jwell Machinery Co., Ltd. is another important development strategic base under Jwell machinery. It is located in Quanjiao County, Chuzhou City with beautiful scenery, close to Hefei and Nanjing and convenient high-speed rail transportation. Jwell machinery is founded in 1997 and a vice president unit of China Plastics Machinery Industry Association and a professional manufacturer of plastic extrusion machinery and chemical fiber spinning complete sets of equipment. Now It has eight production bases, including Anhui Quanjiao, Zhejiang Haining, Suzhou Taicang, Changzhou Liyang, Shanghai Jiading, Zhejiang Zhoushan, Guangdong Foshan and Thailand Bangkok, covering an area of 1000 + mu, It has 26 professional companies, nine large-scale gold processing workshops and three heat treatment nitriding workshops, and produces 3000+ (sets) sets of high-grade plastic extrusion production lines and other complete sets of equipment every year, which sell well in more than 120 countries and regions.

"Excellent Quality, Perfect All" is Jwell's quality policy, and all staff's working direction.

"Be honest" is the core idea for us to contribute "Century JWELL"

President: He Haichao Mobile /WhatsApp +86 13601628188

异向平行双螺杆挤出机

Counter Parallel Twin Screw Extruders

本公司生产的SJP各系列异向平行双螺杆挤出机 主要用来生产加工PVC管材、型材、片板材制品，具有产量高，塑化好，节能降耗，运行平稳等显著特点，电气控制配置先进，可以按照客户的要求选择电脑柜或仪表柜等。

All kinds of SJP extruders that our company designs especially for producing the PVC pipe ,profile sheet and plate, our extruders can promise a good plasticization, high capacity and advanced electric control, and the electrical cabinet can be chosen by customer according to their own demands.



技术参数 Technical parameter

型号 Model	SJP75/28	SJP93/28/31	SJP110/28/31	SJP120/31/26	SJP135/31
螺杆转速 rpm	45	45	45	45	45
电机功率 KW	45	75	110	132/110	160
生产能力 kg/h	150/250	250/400	400/500	500/700	1000/1300
中心高 mm	1050	1050	1050	1100	1100
净重 kg	4100	4700	6500	7500	8400

备注：以上规格参数如有变更，恕不另行通知。 Note: The specifications are subject to change without prior notice.

异向锥形双螺杆挤出机

Counter Rotating Conical Twin Screw Extruders

本公司生产的SJZ各系列异向平行双螺杆挤出机 主要用来生产加工PVC管材、型材、片板材制品，具有产量高，塑化好，节能降耗，运行平稳等显著特点，电气控制配置先进，可以按照客户的要求选择电脑柜或仪表柜等。

All kinds of SJZ extruders that our company designs especially for producing the PVC pipe ,profile sheet and plate, our extruders can promise a good plasticization, high capacity and advanced electric control, and the electrical cabinet can be chosen by customer according to their own demands.



技术参数 Technical parameter

型号 Model	SJZ35/80	SJZ45/100	SJZ51/105	SJZ55/110	SJZ65/132	SJZ80/156	SJZ92/188	SJZ110/220
螺杆转速 rpm	34.7	34.7	34.7	34.7	34.7	34.7	34.7	34.7
电机功率 KW	11/15	15	18.5	22	37/30	55	110	160
生产能力 kg/h	30/50	60/80	80/120	100/150	180/250	300/400	600/800	1200/1400
中心高 mm	1050	1050	1050	1050	1050	1050	1100	1100
净重 kg	1800	2500	3000	3500	4000	5500	8000	10000

备注：以上规格参数如有变更，恕不另行通知。 Note: The specifications are subject to change without prior notice.

锂电池挤出机

Lithium Battery Extruders

该主机主要是根据配套厂家量身定制，利用我们在部件方面的优势，目前已形成合作的厂家很多，性能稳定。

The machine is mainly customized according to the production manufacturers, recently we have successfully cooperation with many customers and machine running very stable because of our advantages in the main parts.



技术参数 Technical parameter

机型 Model	长径比 L/D	转速 rpm Speed	参考产量kg/hr Capacity range
CJWA95	64-68	500-600	根据配方
CJWA110	64-68	500-600	根据配方

备注：以上规格参数如有变更，恕不另行通知。Mote: The specifications are subject to change without prior notice.

CJWS Plus超高扭矩系列挤出机

Main Parameters for CJWS Plus Super-high Torque Series Twin Screw Extruders

CJWS Plus系列双螺杆挤出机面向国内外追求极致品质客户群，力所能及达到最高品质、最强性能与最优可靠性。

CJWS Plus series twin-screw extruders mainly focus on high level customers all around the world, pursuing the best quality, the best performance and the highest liability.



技术参数 Technical parameter

机型 Model	螺杆外径 mm Diameter	长径比 L/D	螺杆转速 rpm Screw speed	电机功率 KW Motor power	单根螺杆扭矩 N.m Torque per shaft	扭矩等级 T/A ³ Specific torque	参考产量kg/hr Capacity range
CJWS35 Plus	35.7	24~68	600	45	365	13.5	120-240
CJWS40 Plus	41.3	24~68	600	75	554	13.5	190-380
CJWS52 Plus	51.7	24~68	600	132	1073	13.5	330-660
CJWS65 Plus	62.7	24~68	600	250	1898	13.5	625-1250
CJWS75 Plus	71.4	24~68	600	355	2916	13.5	890-1760
CJWS85 Plus	81.4	24~68	600	550	4207	13.5	1370-2740
CJWS95 Plus	93.5	24~68	600	800	6406	13.5	2000-4000
CJWS110 Plus	110.6	24~68	500	1100	10512	13.5	2750-5500
CJWS120 Plus	120.6	24~68	500	1450	13500	13.5	3620-7240
CJWS135 Plus	132.5	24~68	400	1500	17969	13.5	3750-7500

备注：以上规格参数如有变更，恕不另行通知。Mote: The specifications are subject to change without prior notice.

CJWV 深槽系列挤出机

Main Parameters for CJWV Large Volume Series Twin Screw Extruders

CJWV系列双螺杆挤出机侧重于高填充类、反应型及较为蓬松类物料体系，主要针对低比功耗作业；更大工作容积和高扭矩、高转速的结合，追求更优化的效率与工艺合理性平衡。

CJWV series twin-screw extruder mainly focused on high filling, reactive or fluffy material system for low SEI application. The combination of large-volume, high torque and high speed reach much optimized balance of efficiency and process rationality.



技术参数 Technical parameter

机型 Model	螺杆外径 mm Diameter	长径比 L/D	螺杆转速 rpm Screw speed	电机功率 KW Motor power	单根螺杆扭矩 N.m Torque per shaft	扭矩等级 T/A ³ Specific torque	参考产量kg/hr Capacity range
CJWV44	42.6	24~68	600	37	308	9	150~300
			800	55			220~440
CJWV55	53.2	24~68	600	75	596	9	300~600
			800	110			440~880
CJWV66	64.0	24~68	600	132	1055	9	530~1060
			800	185			740~1480
CJWV77	74.0	24~68	600	200	1620	9	800~1600
			800	250			1000~2000
CJWV86	83.6	24~68	600	280	2337	9	1100~2200
			800	400			1600~3200
CJWV100	96.0	24~68	600	450	3559	9	1800~3600
			700	500			2000~4000
CJWV110	110.6	24~68	500	560	5468	9	2200~4400
			700	750			3000~6000
CJWV125	123.0	24~68	500	750	7500	9	3000~6000
			600	900			3600~7200
CJWV140	135.6	24~68	400	800	9983	9	3200~6400
			500	1000			4000~8000

备注：以上规格参数如有变更，恕不另行通知。Note: The specifications are subject to change without prior notice.

聚氨酯/TPU反应挤出机

PU/TPU Reaction Extruders

根据聚氨酯/TPU物料流变特性，我公司对筒体的加工精度及筒体的冷却效果方面进行大胆的尝试，同时对一些关键部件进行了升级再设计，基本解决了一些制约物料生产过程中的一些瓶颈性问题，反应的效率及产能得到大幅度的提升，客户反应良好，认同度高。

According to the PU/TPU raw material rheological speciality, We made a lot of efforts on the barrel processing accuracy and barrel cooling effect. Meanwhile, we updated and redesigned the core parts, so that we basically solved some bottleneck problems in the production process. The reaction efficiency and output capacity have been improved sharply and customers approve it.



技术参数 Technical parameter

机型 Model	长径比 L/D	转速 rpm Speed	参考产量kg/hr Capacity range
CJWH75	44-56	300-500	500-700
CJWH95	44-56	300-500	1000-1500

备注：以上规格参数如有变更，恕不另行通知。Note: The specifications are subject to change without prior notice.

硅酮胶系列挤出机

Silicone Adhesive Extruders

硅酮胶系列主要一直是我公司优势产品之一，得益于多年的技术累积和客户的不断反馈，技术成熟，设备运行稳定，深受客户好评。

Silicone adhesive serial equipment has been always one of our superior products, on base of years of technology accumulation and customers' feedback, the silicone equipment became the competitive products with proven technology, steady running and good reputation.



技术参数 Technical parameter

机型 Model	长径比 L/D	转速 rpm Speed	参考产量kg/hr Capacity range
CJWV77	48-64	600-700	2000-2500
CJWV100	48-64	600-700	3000-4000

备注：以上规格参数如有变更，恕不另行通知。 Note: The specifications are subject to change without prior notice.

木塑造粒挤出机

WPC Pelletizing Extruders

同向双螺杆木塑造粒线，通过多年的摸索和总结，可根据客户的生产需要，定制普通常规机型和高产高耐用机型。

WPC co-rotating parallel twin screw pelletizing machine, through years of summarizing we could make conventional machine or high capacity and durable machine according customer's requirement.



技术参数 Technical parameter

机型 Model	长径比 L/D	转速 rpm Speed	参考产量kg/hr Capacity range
CJWA75	40-44	500-600	500-600
CJWA95	40-44	400-500	1000-1200

备注：以上规格参数如有变更，恕不另行通知。 Note: The specifications are subject to change without prior notice.

PVC高速门窗型材生产线

PVC High Speed Profile Extrusion Line

技术参数 Technical parameter

型号model	YF240	YF240	YF240A
制品最大宽度 Production width (mm)	240	240	150*2
主机型号 Extruder model	SJP75/28	SJP93/28/31	SJP110/28
最大挤出量 Output (kg/h)	150-250	250-400	400-500
主机功率 Extruder power (kw)	37	55	75
冷却水用量 Cooling water (m³/h)	7	8	10
压缩空气用量 Compressor air (m³/min)	0.6	0.6	0.8

备注：以上规格参数如有变更，恕不另行通知。 Mote: The specifications are subject to change without prior notice.

型号Model	SJZ55/110	SJZ65/132	SJZ80/156
螺杆功率 rpm	34.7	34.7	34.7
电机功率 kw	22	37/30	55
生产能力 kg/h	100/150	180/250	300/400
中心高 mm	1050	1050	1050
净重 Net weight(kg)	3500	4000	5500

备注：以上规格参数如有变更，恕不另行通知。 Mote: The specifications are subject to change without prior notice.

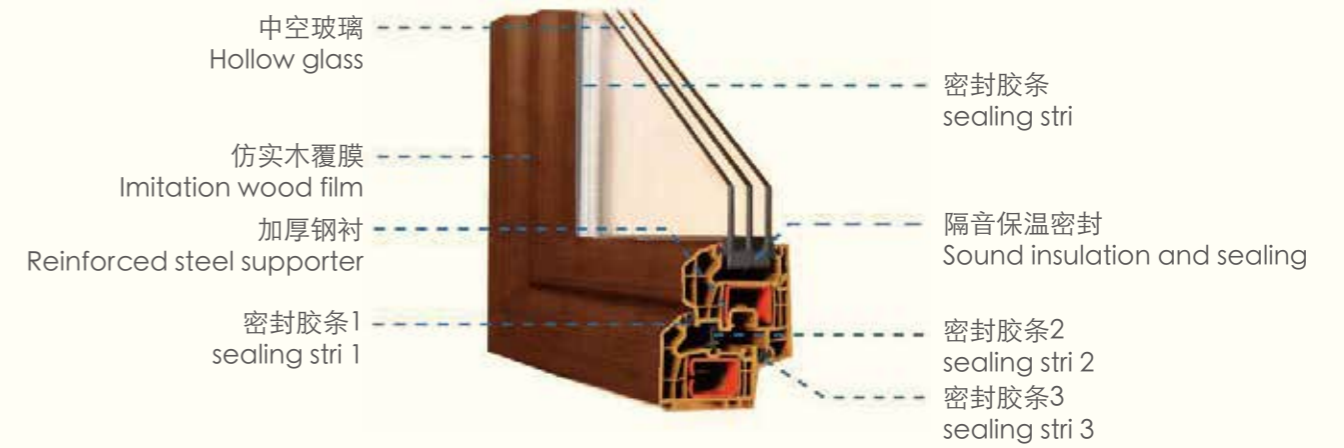

性能和优点：

参照国外新技术，对机组进行优化设计，具有塑化均匀，剪切速率小，产量高，使用寿命长等优点。该机组有双螺杆挤出机、真空定型台、牵引机、切割机、贴膜机、翻料架等组成。主机采用进口交流变频或直流调速拖动，温控仪表采用进口品牌。辅机真空泵和牵引电机均采用优质产品，维护简便，更换螺杆机筒及模具后，可以直接挤出仿真木发泡异型材，效果比单螺杆更佳。

Properties and advantages:

This line features stable plasticization, high output, low shearing force, long life service and other advantages. The production line consists of control system, conical twin screw extruder or parallel twin screw extruder, extrusion die, calibration unit, haul off unit, film covering machine and stacker. The extruder is equipped with AC variable frequency or DC speed drive, imported temperature controller. The calibration unit's pump and haul off unit's reducer are famous brand products. After simple changing of the die and screw and barrel, it also can produce the foam profiles, the effect can be better than single screw extruder.



PVC/WPC中空门板挤出生产线

PVC/WPC Wood Plastic Hollow Door

该生产线可以生产宽幅为 600-1200 之间任何规格宽幅的 PVC 塑木门板，设备主要有 SJZ92/188 锥形双螺杆挤出机、定型台、牵引机、切割机、放料架等组成，设备配置先进，制作精良，主要电气控制元件采用优质品牌，挤出系统设计中吸取了国外同行业先进技术成果，可靠性和耐久性程度高。辅机现有两种配置：YF1000和 YF1250，可供广大用户选择。

The production line can produce the PVC wood-plastic door of the width between 600 and 1200 .the device has SJZ92/188 conical twin screw extruder, calibration, hall-off unit, cutter, such as stacker,targeting the advanced equipment, well-produced, the main electrical control devices are well-known global brands, extrusion system design imbibes the technic of for- eign country in this line, and it has a highly dependability and wearness.The other scheme have two types:it's supply for the custom to choose: YF1000 and YF1250.

技术参数 Technical parameter

辅机型号 Model	YF800	YF1000	YF1250
制品最大宽度 Production width (mm)	800	1000	1250
主机型号 Extruder model	SJZ80/156	SJZ92/188	SJZ92/188
辅机型号 Type	YF800	YF1000	YF1250
主机驱动功率 Extruder power (KW)	55	110	110
最大挤出量 Max of extrusion capacity (Kg/h)	250-350	400-600	400-600
冷却水用量 Cooling water (m³/h)	12	15	15
压缩空气用量 Compressor air (m³/min)	0.6	0.6	0.6

备注：以上规格参数如有变更，恕不另行通知。 Note: The specifications are subject to change without prior notice.



PVC结皮(木塑)发泡板材生产线

PVC Skinning (WPC) Foaming Board Extrusion Line

PVC发泡板及木塑发泡板的应用

交通运输业：轮船、飞机、客车、火车车厢、顶蓬、厢体芯层、内部装饰用板。

建筑装潢业：建筑物外墙板、内装饰用板、住宅、办公室、公共场所建筑物隔间、商用装饰架、无尘室用板、吊顶板、家庭橱柜、吊柜和家居。通过油漆印刷、贴膜和热压设备，可以生产各类仿木制品。

结皮（木塑）发泡生产线

该设备为发泡板行业根据自由发泡和结皮发泡的特点，采用自由发泡设备的挤出部分和结皮发泡的定型辅机部分发展而来的。具有产品质量兼有结皮发泡的平整度、自由发泡设备的低密度、表面硬度间于结皮发泡和自由发泡之间的特点；另外设备投资小，接近自由发泡设备，利于市场的推广。

技术参数 Technical parameter

机型	结皮发泡板	共挤发泡板
Model	Skinning foaming board extrusion line	Co-extrusion foamed board extrusion line
制品宽度 Products Width(mm)	1220-1600	1220-1600
制品厚度 Products Thickness(mm)	3-30	3-30
挤出机规格 Extruder Specification	SJZ80/156	SJZ65/132、SJZ80/156
最大挤出产量 Capacity (Max.)(Kg/h)	300-400	400-500
主电机功率 Main Motor Power(Kw)	75	37/75

备注：以上规格参数如有变更，恕不另行通知。Note: The specifications are subject to change without prior notice.

PVC foaming board and WPC foaming board application:

Transportation industrial: Ship, plane, bus, chamber of train, roofing, core layer, inner decoration board. Construction and decoration industrial: outer wall board, inner decoration board, housing, office, public construction board, furniture, cupboard, roofing. Adopting printing, film coating and thermoembossing equipment, will get all kinds of emulational wooden product.

Skinning(WPC) foam board extrusion line

This extrusion line is made according to the features of free foamed board and skinning foamed board by using the extrusion system for free foamed board machine and the downstream equipment for skinning foamed board. The product produced by this machine has the features of smooth surface, low density, and the surface hardness of the product is between the skinning foamed board and free foamed board. The investment of this machine is close to the investment of free foamed board extrusion line, which makes it easy for market promotion.



PVC发泡异型材生产线

PVC Foaming Profile Extrusion Line

该生产线主要用于生产木塑装饰材料，制品广泛用于家装和工装市场，具有无污染高寿命、抗冲击、保温隔热、防水防潮、防火阻燃、易安装易擦洗、高效省时、时尚美观、可回收利用等特点。制品可用于高档墙饰面、吊顶、门套、吸音、保温要求的场所。

The production line is mainly used to produce wood plastic decorative materials. The products are widely used in home decoration and industrial installation market, characteristics with pollution-free, long service life and impact resistance, thermal insulation, waterproof and moisture-proof, fire retardant and easy to install and clean, efficient and time saving, fashionable and beautiful, recyclable etc... Profile product' s can be used for high-grade wall decoration, ceiling, door frame, sound insulation, and places with insulation requirements.

技术参数 Technical parameter

主机型号 Extruder type	SJZ51/105	SJZ65/132	SJZ80/156
制品最大宽度 Production width (mm)	180	300/400	600
主电机功率 Motor power (kw)	22	37	55
辅机型号 Auxiliary machine model	YF180	YF300/400	YF600
最大挤出量 Output (kg/h)	80-100	150-200	300-400
冷却水用量 Cooling water consumption(m ³ h)	6	7	8
压缩空气用量 Compressor air consumption(m ³ h)	0.6	0.6	0.6

备注：以上规格参数如有变更，恕不另行通知。Note: The specifications are subject to change without prior notice.

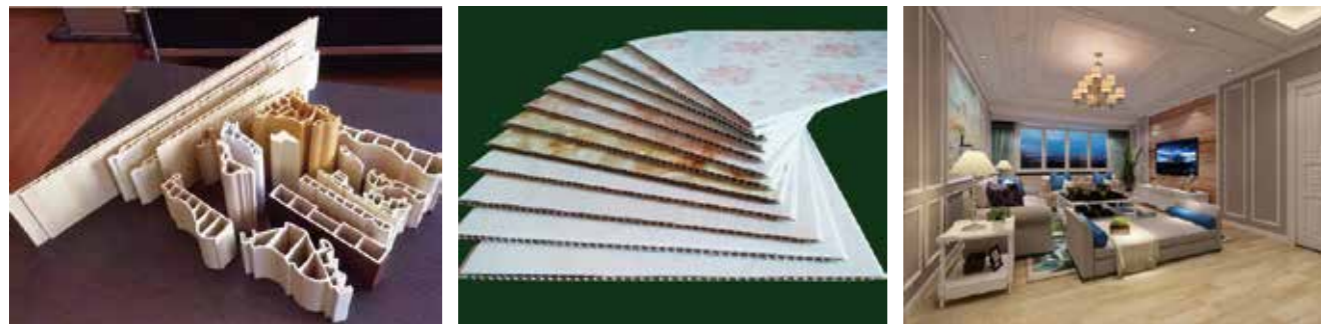

PVC自由发泡/仿大理石板挤出生产线

PVC Free Foaming/UV Imitation Marble Board Extrusion Line

应用

- 广泛应用于网板印刷、电脑刻字、广告标示、展板、标志用板、相册板等行业。
- UV仿大理石板
- a、板材表面覆仿大理石纹薄膜，或者热转印仿大理石纹并 UV固化处理，良好的抗划伤性，耐刮擦性；
- b、板材花色、品种多样，施工方便；
- c、在室内墙体装潢中替代大理石等天然石材，良好的耐老化性、抗紫外线、耐黄变，绿色环保、无辐射。



Application :

- PVC free foamed board is widely used in advertisement board, exhibition board, picture frame, etc.
- UV imitation marble board:
- a、Board surface coat imitation marble film, or laminate imitation marble and through curing treatment, good anti scratch, anti scratch resistance. b、Board with variety of color, it's convenient to construct;
- c、Instead of marble etc. natural stone in the interior decoration, with good aging resistance、anti-ultraviolet ray、anti-yellow, green and environment、no radiation.



技术参数 Technical parameter

机型Model			
制品宽度 Products Width(mm)	1220	1560	2050
制品厚度 Products Thickness(mm)	1-18	1-12	1-10
挤出机规格 Extruder Specification	SJZ80/156	SJZ80/156	SJZ80/156
最大挤出产量 Capacity (Max.)(kg/h)	350-450	350-450	350-450
主电机功率 Main Motor Power(Kw)	75	75	75

备注：以上规格参数如有变更，恕不另行通知。Note: The specifications are subject to change without prior notice.

PVC线槽挤出生产线

PVC Plastic Trunk Extrusion Line

PVC线槽只是线槽的一种，主要是用于电气设备内部布线，现在普遍使用的有环保阻燃PVC线槽。

- 1、PVC线槽具有绝缘、防弧、阻燃自熄等特点，
- 2、PVC线槽主要起到机械防护和电气保护的作用。
- 3、PVC线槽配线方便、布线整齐、安装可靠，还便于查找、维修和调换线路。

PVC trunk is a kind of trunks, which is mainly used for internal wiring routing of electrical equipment. Now, environmentally friendly & flame retardant PVC trunk is widely used.

1. PVC trunk has the characteristics of insulation, arc protection, flame retardant and self extinguishing etc characteristics.
2. PVC trunk mainly plays important role of mechanical protection and electrical protection.
3. PVC trunk is convenient for wiring, neat wiring routing, reliable installation, and also easy to find, repair and replace wire routing line.



技术参数 Technical parameter

机型 Model	SJZ51	SJZ55	SJZ65
螺杆规格 Screw size	51/105	55/110	65/132
主电机功率 Motor power(KW)	18.5	22	37
产能 Output(kg/h)	80-100	100-150	150-200

备注：以上规格参数如有变更，恕不另行通知。Note: The specifications are subject to change without prior notice.

WPC (PE&PP) 木塑地板挤出生产线

WPC (PE&PP) Wood-plastic Floor Extrusion Line

WPC (PE&PP) 木塑地板是指木塑复合材料的配混、脱挥、制品挤出成型分别在不同的设备中完成，即原材料按一定配方配混好之后，中间造成木塑颗粒，再挤出加工成木塑地板的这个过程。

目前两步法应用较为广泛：一般是用锥双挤出机或平双挤出机造粒，再用锥双或单螺杆挤出机挤出成型制品，主要使用在室内外地板、护栏、托盘等WPC (PE&PP) 类木塑产品的挤出成型。

WPC (PE&PP) Wood-Plastic Floor is that the wood-plastic composite materials complete in different equipments of mixing, from play, extruding products, mixing the raw material in a certain formula, forming wood-plastic particles in the middle, and then squeezing out products. And nowadays, the two-step way is used currently, application of a wider general use dual cone or two-extruder extruder granulation, and then double-cone or single screw extruder extrusion products, mainly used in floor indoor or outdoor, parapets, tray, such as WPC (PE&PP) plastic extrusion products.

技术参数 Technical parameter

型号Model	SJZ65	SJZ72	SJZ80
螺杆规格 Screw size	65/132	72/152	80/156
主电机功率 Power of main motor(KW)	37	45	55
生产能力 Output(kg/h)	150-180	125-300	200-350

备注：以上规格参数如有变更，恕不另行通知。Note: The specifications are subject to change without prior notice.



海洋踏板挤出生产线

PE Marine Pedal Profile Extrusion Line

金纬机械为建设绿色海洋牧场助力!

传统的近海网箱养殖以木质网箱、木质渔排和塑料泡沫为主要生产资料，在生产养殖前后都会对海域造成严重污染，而且抗风浪、抗风险能力弱，存在安全隐患。目前金纬机械提供的整套项目解决方案包括塑胶渔排踏板挤出生产线 + 海洋浮桶中空吹塑成型机 + 海洋管材生产线，是未来海洋养殖的趋势，该产品具有绿色环保，可回收，抗台风、抗老化、抗紫外线等一系列优点，保障了海洋的生态环境免遭破坏，国外已经在推广，国内沿海养殖区正在慢慢普及。

主要用于海上，也可用于江、河、湖、泊、塘等。

Jwell Machinery helps to build a green marine ranch!

Traditional offshore culture in net cage mainly uses wooden net cage, wooden fishing raft and plastic foam. It will cause serious pollution to the sea area before and after the production and cultivation, and it's also weak in resisting wind waves and resisting risks. At present, the whole set of project solutions provided by Jwell Machinery include Plastic Fishing Raft pedal extrusion extrusion line + marine floating bucket blow moulding machine + marine pipe extrusion line, which is the trend of marine aquaculture in the future. This product has a series of advantages, such as green environment protection, recyclability, typhoon resistance, anti-aging, anti-ultraviolet ray and so on. It ensures the marine ecological environment from being destroyed. It has been promoted abroad. Domestic coastal aquaculture areas are gradually popularizing.

Mainly used in the sea, can also be used in rivers, lakes, moors, ponds, etc.



PVC/PP/PE/PC/ABS等异型材挤出生产线

PVC/PP/PE/PC/ABS Small Profile Extrusion Line

本公司吸取了国内外先进技术，成功开发出适合用户需求的小型材生产线。该机组有单螺杆挤出机或双螺杆挤出机、真空定型台、牵引机、切割机、翻料架等几部分组成，生产线具有塑化好，产量高，能耗低等显著特点。主机采用进口交流变频器调速，温控仪表采用日本 OMRON 欧姆龙产品。辅机真空泵和牵引电机均采用优质产品，维护简便。

By adopting the foreign and domestic advanced technology, we successfully developed the small profile extrusion line. This line consists of Single Screw Extruder, Vacuum Calibration Table, Haul-off Unit, Cutter and Stacker, the producing line features of good plasticization, high output capacity, low power consumption and etc. The main extruder speed controlled by imported AC inverter, and temperature control by Japanese OMRON temperature meter, vacuum pump and traction gear reducer of the down stream equipment are all good quality products, and also easy maintenance.

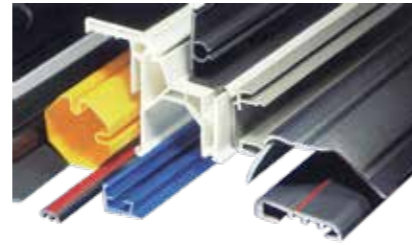

技术参数 Technical parameter

型号Model	YF50	YF108	YF180	YF240	YF300
制品最大宽度 Production width (mm)	50	108	180	240	300
主机型号 Extruder model	JWS 45	JWS 50	JWS 65	JWS 90	JWS 120
驱动功率(kw)	15/11	22/18.5	30/22	55/45	90/75
冷却水用量 Cooling water (m ³ /h)	4	4	5	7	7
压缩空气用量 Compressor air (m ³ /min)	0.5	0.6	0.6	0.6	0.6

备注：以上规格参数如有变更，恕不另行通知。 Mote: The specifications are subject to change without prior notice.



PVC/TPU/TPE密封条生产线

PVC/TPU/TPE Sealing Strip Profile Extrusion Line

该生产线主要用于加工 PVC、TPU、TPE 等不同材料的密封条，性能稳定产量高、能耗低等特点。主机采用进口交流变频调速，西门子显示屏，操作简单，维护方便。

The machine is used for producing sealing strip of PVC, TPU, TPE etc material, features high output, steady extrusion, low power consumption. Adapting famous inverter, SIEMENS PLC and screen, easy operation and maintenance.

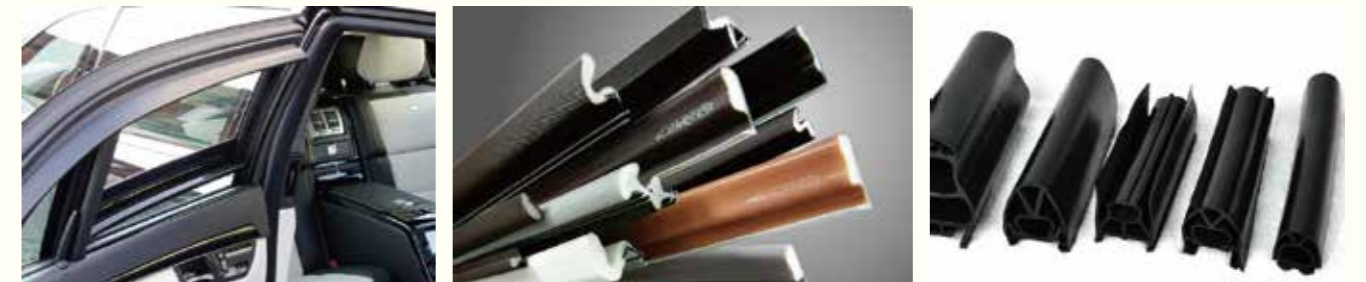

技术参数 Technical parameter

主机型号 Extruder model	JWS45/28	JWS65/28
主机马达 Motor power (kw)	7.5	18.5
最大挤出量 Output (kg/h)	15-25	40-60
冷却水用量 Cooling water (m ³ /h)	3	4
压缩空气用量 Compressor air (m ³ /min)	0.6	0.6

备注：以上规格参数如有变更，恕不另行通知。 Mote: The specifications are subject to change without prior notice.



生物降解塑料改性造粒挤出生产线

Bio-degradable Plastics Compounding Extrusion Line

典型应用为PLA、PBAT、PBS、PPC、PCL、TPS和PHA等全降解塑料的合金共混，淀粉填充改性，竹木粉填充改性，矿物粉填充改性等。

Typical application as plastic alloy, starch filled compound, bio-mass filled compound or mineral powder filled compound for bio degradable plastics as PLA, PBAT, PBS, PPC, PCL, TPS and PHA etc.



技术参数 Technical parameter

机型 Model	长径比 L/D	转速 rpm Speed	参考产量kg/hr Capacity range
CJWH-52	40-56	300	150
CJWH-65	40-56	300	240
CJWH-75	40-56	300	440
CJWH-95	40-56	300	820
CJWS-52	40-56	300	190
CJWS-65	40-56	266	310
CJWS-75	40-56	300	550
CJWS-95	40-56	300	1060
CJWS-75 Plus	44-56	330	700

备注：以上规格参数如有变更，恕不另行通知。Note: The specifications are subject to change without prior notice.

石化类粉体造粒及粉体改性挤出生产线

Petrochemical Powder Pelletizing and Powder Modification Extrusion Line

石化类粉体造粒和粉体改性是同向双螺杆挤出机最主要的应用之一，通过不断努力，优化改进，整合行业资源，已获得市场广泛的认同。

Petrochemical powder pelletization and powder modification are one of the most important applications for twin screw extruder. Through continuous efforts, optimization and improvement, the integration of industry resources has been widely recognized by the market.



技术参数 Technical parameter

机型 Model	长径比 L/D	转速 rpm Speed	参考产量kg/hr Capacity range
CJWS75	44-56	600-1000	800-1500
CJWS95	44-56	600-800	1200-2000
CJWS110	44-56	500-600	2000-3000
CJWS135	44-56	500-600	3000-4500
CJWS145	36-48	400	5000-7000

备注：以上规格参数如有变更，恕不另行通知。Note: The specifications are subject to change without prior notice.

热塑性弹性体造粒挤出生产线

Thermoplastic Elastomers Pelletizing Extrusion Line

热塑性弹性体为当前最有潜力的新材料之一，同时兼具塑料和橡胶的优点，广泛适用于汽车、电气、工程、医疗等其他领域。

Thermoplastics are the most potential new material at present, combining both advantages of plastic and rubber, which can be used in automobile, electronics, engineering and medical, etc.

● TPS ● TPU ● TPV ● TPEE ● TPO



技术参数 Technical parameter

机型 Model	长径比 L/D	转速 rpm Speed	参考产量kg/hr Capacity range
CJWH65	48-64	300-600	300-500
CJWH75	48-64	300-600	500-1000
CJWH95	48-64	300-600	1000-1500

备注：以上规格参数如有变更，恕不另行通知。Mote: The specifications are subject to change without prior notice.

工程塑料造粒挤出生产线

Engineering Plastics Pelletizing Extrusion Line

此应用为双螺杆配混应用的主要领域，可用于高分子着色改性、填充共混改性、以及其他各种力学、电学、热学、光学、耐环境及耐生物性能改性等。

This type main application to twin screw compounding filed, which can be used for polymer coloring, filling and blending, and also other mechanics, electrical, thermoplastics, optical, processability, and anti-environment and anti-biological function modification.



技术参数 Technical parameter

机型 Model	长径比 L/D	转速 rpm Speed	参考产量kg/hr Capacity range
CJWH65	36-48	400-900	300-800
CJWH75	36-48	400-900	500-1000
CJWH95	36-48	400-900	800-1500

备注：以上规格参数如有变更，恕不另行通知。Mote: The specifications are subject to change without prior notice.

PET 瓶片回收造粒挤出生产线

PET Bottle Flakes Recycling & Pelletizing Extrusion Line

PET瓶片回收的过程中对粒子的粘度有严格的要求，通过多年努力，不断累积，公司针对该市场开发了两类产品供客户选择，一种是经济型，采用普通的拉条切粒方式，另一种是高产节能型，采用先进的水中拉条切粒方式，操作简单，维护方便。

PET bottle flakes in the process of recycling has strict requirements to the viscosity of the granules, through years of hard search, steady accumulation, our company has developed two kinds of production according to the market for customer option, one is economical, using common way to water cooling strand pelletizing, the other is a high energy-saving, adopt advanced strand cutting in water, simple operation, convenient maintenance.



技术参数 Technical parameter

机型 Model	长径比 L/D	转速 rpm Speed	参考产量kg/hr Capacity range
CJWH75	40-48	300-500	300-500
CJWH85	40-48	300-500	400-600
CJWH95	40-48	300-500	1000-1200

备注：以上规格参数如有变更，恕不另行通知。Note: The specifications are subject to change without prior notice.

LFT-G长纤浸渍增强热塑性复合材料造粒生产线

Long-Fiber Reinforce Thermoplastic Extrusion Line

相比常规短纤维增强，长纤浸渍后增强效果更佳，能达到更高的比强度，耐热性能也得到明显提升。常用的基材有PP和PA，常用的增强纤维有玻璃纤维，碳纤维和玄武岩纤维。

Comparing with traditional short fibre reinforcing, LFT can reach even higher strength and specific strength, the thermal resistance is increased significantly. The resin generally PP and PA, the reinforcing fiber generally glass fiber, carbon fiber or basalt fiber.



技术参数 Technical parameter

机型 Model	参考产量kg/hr Capacity range	典型应用 Typical application
CJWH52	300-400	PP+50%GF

备注：以上规格参数如有变更，恕不另行通知。Note: The specifications are subject to change without prior notice.

PVC异向平双螺杆造粒挤出生产线

PVC Counter Parallel Twin-screw
Pelletizing Extrusion Line

该机组是由系列平双螺杆挤出机与相应造粒辅机组成的成套设备，主要适用于 PVC 软质，硬质造粒。生产的塑料颗粒均匀、密实、美观，辅机采用模面切粒，风送集料，振动分离冷却，具有自动化程度高，生产效率佳等特点。

This pelletizing machine is composed by a counter parallel twin-screw extruder and downstream equipment, it is suitable for the pelletizing of PVC soft and rigid. The pellets produced by this machine is evenly, solid, elegance. The pelletizing down-stream equipment is the die face cutter, air transferring unit, vibration separating and cooling unit. This pelletizing down-stream equipment has the features of high automation and high production efficiency.

技术参数 Technical parameter

型号Model	SJP95	SJP120	SJP135
螺脚格 (mm)	95/22	120/26	135/31
颗粒规格 (mm)	Φ3-Φ4	Φ3-Φ5	Φ3-Φ5
生产能力 Output(Kg/h)	200-350	500-600	800-1200
主电机功率 Power of main motor(Kw)	55	110	160

备注：以上规格参数如有变更，恕不另行通知。Mote: The specifications are subject to change without prior notice.



PVC异向锥双螺杆造粒挤出生产线

PVG Counter Conical Twin-screw
Pelletizing Extrusion Line

该机组是由系列锥双螺杆挤出机与相应造粒辅机组成的成套设备，主要适用于 PVC 软质，硬质造粒。生产的塑料颗粒均匀、密实、美观，辅机采用模面切粒，风送集料，振动分离冷却，具有自动化程度高，生产效率佳等特点。

This pelletizing machine is composed by a counter conical twin-screw extruder and downstream equipment, it is suitable for the pelletizing of soft and rigid PVC. The pellets produced by this machine is evenly, solid, elegance. The pelletizing down-stream equipment is the die face cutter, air transferring unit, vibration separating and cooling unit. This pelletizing down-stream equipment has the features of high automation and high production efficiency.

技术参数 Technical parameter

型号Model	SJZ65	SJZ80	SJZ92	SJZ110
螺杆规格 (mm)	65/132	80/156	92/188	110/220
生产能力 Output(Kg/h)	200-300	300-500	600-800	800-1200
主电机功率 Power of main motor(Kw)	37	55	110	160

备注：以上规格参数如有变更，恕不另行通知。Mote: The specifications are subject to change without prior notice.



常规切粒方式示意图

Regular Dicing Schematic Diagram

水下切粒流程示意图

Underwater Pelletizing diagram

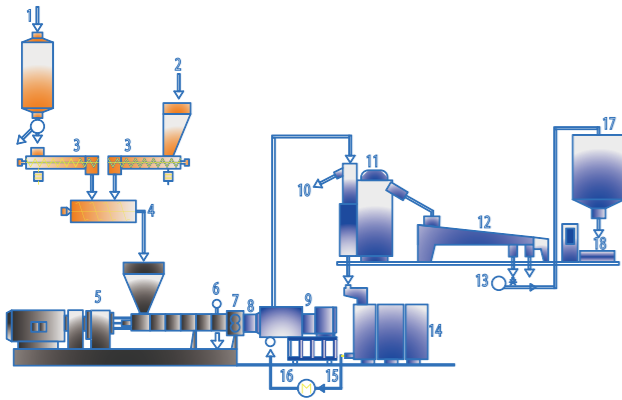

- | | | |
|-----------------|----------|---------|
| 1、PP、HDPE、LLDPE | 7、齿轮泵 | 13、气动输送 |
| 2、添加剂 | 8、液压换网 | 14、水箱 |
| 3、计量加料 | 9、水下切粒 | 15、水泵 |
| 4、输送混合螺杆 | 10、大料溢出口 | 16、换热器 |
| 5、双螺杆挤出机 | 11、干燥机 | 17、料仓 |
| 6、旋转阀 | 12、振动筛 | 18、成品包装 |

- | | |
|----------------------------------|--------------------------|
| 1、LLDPE、PP、HDPE | 10、Overflow outlet |
| 2、Additives | 11、Pellet dryer |
| 3、Loss-in-weight feeder | 12、Classifying screen |
| 4、Screw for conveying and mixing | 13、Pneumatic conveyer |
| 5、Twin screw extruder | 14、Water tank |
| 6、Start-up valve | 15、Water pump |
| 7、Gear pump | 16、Heat exchanger |
| 8、Hydraulic screen changer | 17、Silo |
| 9、Underwater pelletizing | 18、End product packaging |

拉条切粒 (适用于增强、填充、合金、着色)

Strand Pelletizing (suitable for reinforcement, filing, alloy and masterbatch)

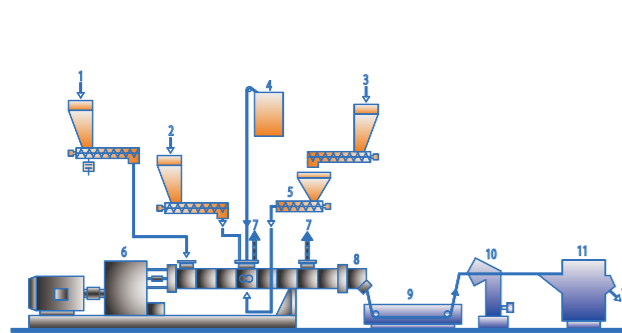

- | | |
|------------|--------|
| 1、预料配混 | 7、排气口 |
| 2、切短纤维 | 8、拉条机头 |
| 3、填料 | 9、水槽 |
| 4、玻璃/碳纤维长丝 | 10、风刀 |
| 5、侧喂料 | 11、切粒机 |
| 6、双螺杆挤出机 | 12、到包装 |

- | | |
|-----------------------|-------------------|
| 1、Material pre-mixing | 7、Venting port |
| 2、Chopped glass fiber | 8、Strand die head |
| 3、Fillers | 9、Water trough |
| 4、Glass/carbon fiber | 10、Air knife |
| 5、Side feeder | 11、Pelletizer |
| 6、Twin screw extruder | 12、To packing |

水环切粒

Water-ring pelletizing

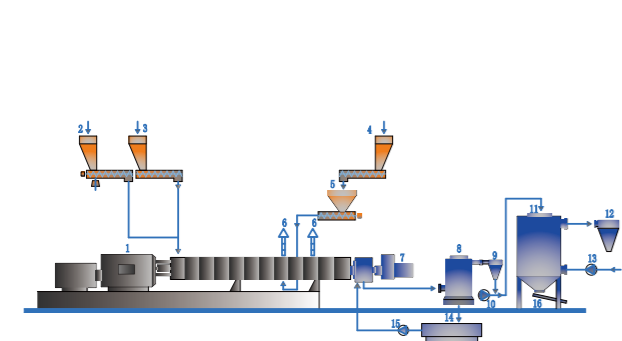

- | | | |
|----------|---------|---------|
| 1、双螺杆挤出机 | 7、水环切粒 | 13、沸腾风机 |
| 2、加料口一 | 8、离心脱水机 | 14、水池 |
| 3、加料口二 | 9、出料斗 | 15、水泵 |
| 4、填料计量 | 10、输送风机 | 16、到包装 |
| 5、侧喂料 | 11、沸腾床 | |
| 6、排气 | 12、屑料收集 | |

- | | |
|------------------------------|---------------------------------|
| 1、Twin screw extruder | 9、Material discharge hopper |
| 2、Feeding port 1 | 10、Air conveyor |
| 3、Feeding port 2 | 11、Fluidized bed |
| 4、Fillers dosing | 12、Scraps gathering silo |
| 5、Side feeder | 13、Blower fan for fluidized bed |
| 6、Venting | 14、Water tank |
| 7、Water ring pelletizer | 15、Water pump |
| 8、Centrifugal hydroextractor | 16、To packing |

双阶偏心风冷造粒

Two Stage Eccentric Air-cooling Pelletizing

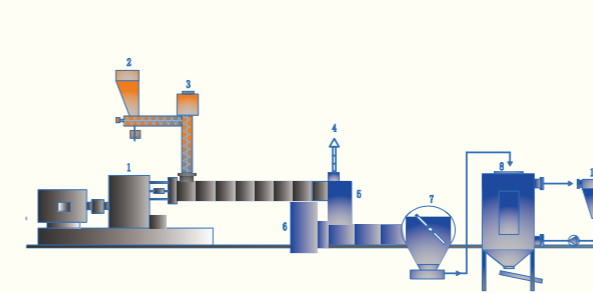

- | | |
|----------|-----------|
| 1、双螺杆挤出机 | 7、偏心风冷切粒机 |
| 2、原料加入 | 8、沸腾床 |
| 3、强制加料 | 9、风机 |
| 4、排气 | 10、收集仓 |
| 5、连接罩 | 11、到包装 |
| 6、单螺杆挤出机 | |

- | | |
|-------------------------|------------------------------------|
| 1、Twin screw extruder | 7、Eccentric air cooling pelletizer |
| 2、Raw material feeding | 8、Fluidized bed |
| 3、Forcing feeding | 9、Blower fan |
| 4、Venting | 10、Gathering silo |
| 5、Connecting cover | 11、To packing |
| 6、Single screw extruder | |

双阶偏心水雾切粒

Two Stage Eccentric Water-fog Pelletizing

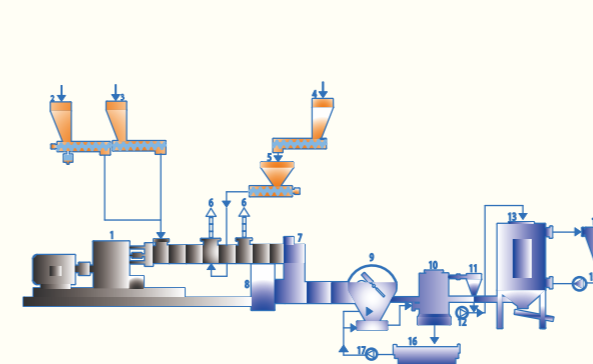

- | | | |
|----------|-----------|----------|
| 1、双螺杆挤出机 | 7、单双连接体 | 13、沸腾床 |
| 2、加料口一 | 8、单螺杆挤出机 | 14、原料收集孔 |
| 3、加料口二 | 9、偏心风冷切粒机 | 15、沸腾风机 |
| 4、填充计量 | 10、离心脱水机 | 16、水池 |
| 5、侧喂料 | 11、出料斗 | 17、水泵 |
| 6、排气 | 12、输送风机 | |

- | | |
|---------------------------------------|---------------------------------|
| 1、Twin screw extruder | 10、Centrifugal hydroextractor |
| 2、Feeding port1 | 11、Material discharge hopper |
| 3、Feeding port2 | 12、Air conveyor |
| 4、Fillers dosing | 13、fluidized bed |
| 5、Side feeder | 14、Gathering silo |
| 6、Venting | 15、Blower fan for fluidized bed |
| 7、Connection of single and twin screw | 16、Water tank |
| 8、Single screw extruder | 17、Water pump |
| 9、Eccentric air-cooling pelletizer | |

风冷造粒生产线

Air-cooling Pelletizing

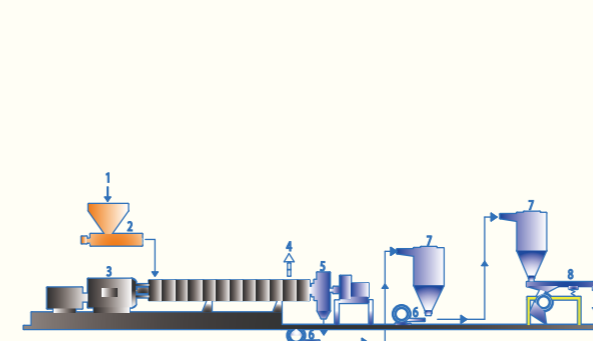

- | | |
|----------|---------|
| 1、料斗 | 5、风冷切粒机 |
| 2、喂料机 | 6、风机 |
| 3、双螺杆挤出机 | 7、旋风分离器 |
| 4、排气 | 8、冷却振动筛 |

- | | |
|-----------------------|---------------------------|
| 1、Hopper | 5、Air-cooling pelletizer |
| 2、Feeder | 6、Blower fan |
| 3、Twin screw extruder | 7、Whirlwind separator |
| 4、Venting | 8、Cooling vibratory sieve |

工艺流程

Flow Chat of WPC Production

Outdoor Products (PE、PP、PS) Flow Chat of WPC Two-step Line

门板室外产品 (PE、PP、PS) 木塑两步法流程图

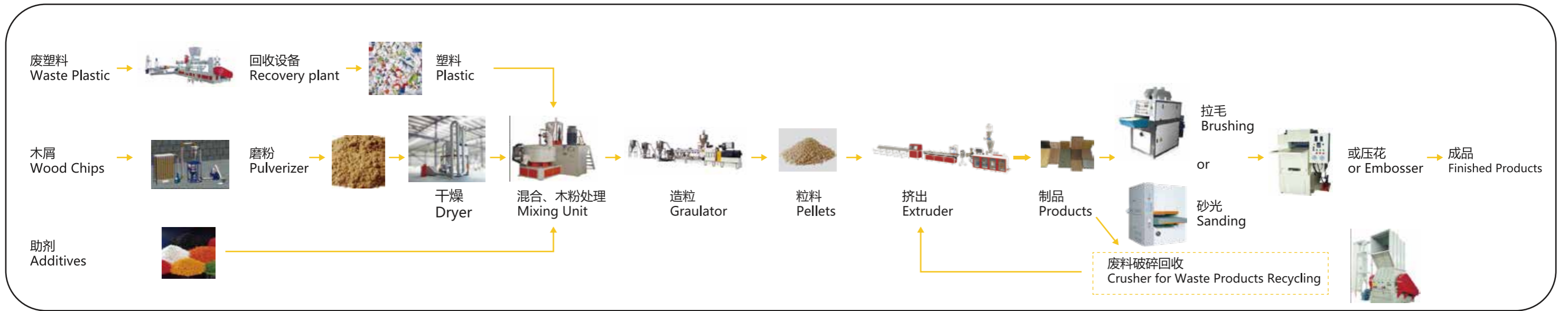

Indoor Products Flow Chat of WPC process

室内产品 (PVC 发泡) 木塑工艺流程图

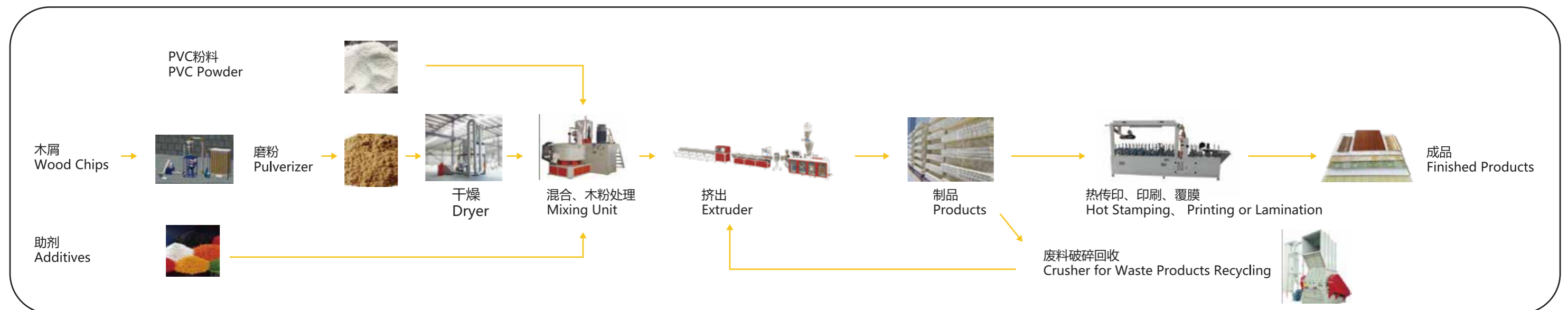

相关产品链接

Linkage of relating auxlary equipment



Gravimetric system

计量称重系统



Hydraulic screen changer

自动换网器和液压站



Mixer

800-2500 卧式混料机



Crusher

破碎机



Extruder

挤出机

Screw and barrel

螺杆、机筒



All kinds of profile tooling

各类木塑型材模具

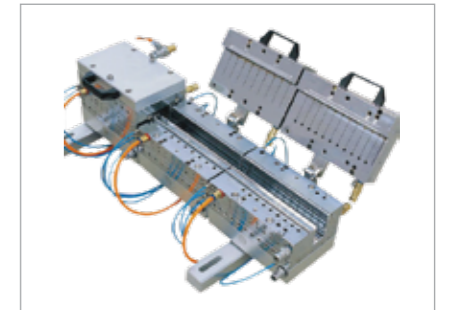

T-die and feedblock

模具和分配器



All kinds of mirror rollers

各类镜面辊筒





实时工况
Real-time operating status

方案 1 免费体验版 (适用于有变频器的设备)
Programme 1 Free experience Edition(suitable for equipment with Inverter)

- 具备功能:
1. 可以监测主机实时电流及电流曲线。
 2. 可以在手机上查看数据信息。
- Function:
1. Monitor the current Electricity and Electricity curve
 2. Monitor the data by the phone.

- 方案优点
1. 随时了解自己设备的开机情况。
 2. 电流曲线记录, 可以展示给最终客户, 用于说明管材或型材制品生产状态稳定, 质量可靠。
 3. 非 PLC 系统的生产线同样可以安装。
- Program advantage:
1. Controlling equipment situation at any time.
 2. Showing the Electricity curve to final customer, that is used to explain the stable production state and reliable quality of pipe or profile products.
 3. Non-PLC system also can be installed in the production line.

方案 2 精优版 (仅适用于 PLC 系统设备)
Programme 2 excellent Edition (suitable for equipment with PLC control system)

- 具备功能:
1. 可以监测主机电流。
 2. 可以监测主机温度。
 3. 可以监测主机电能。
 4. 可以监测主机每吨物料能耗 (目前仅支持有米重控制的设备)。
 5. 可以在手机上查看数据信息。
- Function:
1. Monitor the main Extruder Electricity.
 2. Monitor the main Extruder Temperature .
 3. Monitor the main Extruder Power.
 4. Monitor the energy consumption per ton of material(now just support the meter weight control).
 5. Monitor the data by the phone.

- 方案优点
1. 随时了解自己设备的开机情况。
 2. 随时了解机器的能耗核算出开机成本。
 3. 可向最终客户展示电流曲线、米重曲线等数据, 用于说明管材或型材制品生产状态稳定, 质量可靠。
- Program advantage:
1. Controlling equipment situation at any time.
 2. Monitor the energy consumption of material and calculating the cost of running machine.
 3. Showing the Electricity curve , meter weight curve data and so on ,that is used to explain the stable production state and reliable quality of pipe or profile products.



作业情况统计
Working status statistics

方案 3 精细版 (适用于有 PLC 系统或工控机设备)
Programme 3 detail Edition(Suitable for PLC control system or Industrial control machine equipment)

- 具备功能:
1. 可以监测主机电流。
 2. 可以监测主机温度。
 3. 可以监测主机电能。
 4. 可以监测主机每吨物料能耗 (目前仅支持有米重控制的设备)。
 5. 可以在手机上查看数据信息。
 6. 可以记录并统计设备故障, 部件更换等信息。
 7. 可以连接 MES 系统。
 8. 可以远程调试程序。
- Function:
1. Monitor the main Extruder Electricity.
 2. Monitor the main Extruder Temperature .
 3. Monitor the main Extruder Power.
 4. Monitor the energy consumption per ton of material(now just support the meter weight control).
 5. Monitor the data by the phone.
 6. Record and statistics equipment breakdown situation, parts replacement information and so on .
 7. Connect EMS system
 8. Remote adjustment and control program

- 方案优点
1. 随时了解自己设备的开机情况。
 2. 随时了解机器的能耗核算出开机成本。
 3. 记录电流的大小, 展示给最终客户, 用于说明管材或型材制品生产状态稳定, 质量可靠。
 4. 随时远程检查调试程序, 在机器出问题的情况下用最短的时间检查出故障点, 维修好设备, 将大大降低设备因故障停机的时间, 提高生产效率。
 5. 连接企业生产系统, 便于企业记录并分析相关数据, 更好提升生产效率, 降低设备故障率。
- Program advantage:
1. Controlling equipment situation at any time.
 2. Monitor the energy consumption of material and calculating the cost of running machine
 3. Record electricity size, showing to the final customer ,that is used to explain the stable production state and reliable quality of pipe or profile products.
 4. Remote adjustment and control program with any time. Once the machine has a problem, it will check out the fault point with shortest time and maintenance the equipment ,in order to greatly reduce the time of the equipment due to the machine breakdown and improve the production efficiency.
 5. Connecting enterprise production system, it is convenient for enterprises to record and analyze relevant data, to improve production efficiency and reduce equipment breakdown rate.

Plastic Machinery Fully Integrated Automation + Internet Of Things Control System Solutions

基于 MES 系统平台, 实现车间生产管理的信息沟通平台, 并向智能化方向发展。
Based on the MES system platform, the information communication platform of workshop production management is realized and move toward the intelligent direction

